

Thank you very much for your purchase of the CEC (Catalyst Eliminator Computer) from MaxVolt Performance! The following information will help you to understand how the CEC system connects and interacts with your catalyzed marine engine.

### **Applications**

The CEC kits are applicable to all recreational pleasure craft that use a four wire oxygen sensors at all locations:



*Figure 1 - Four wire oxygen sensor and connector*

If your craft does not use this style of connector on all of the oxygen sensors, this kit is not the correct one for your application!

Kit Part Number 121-1210 is applicable to MerCruiser big blocks, small blocks, and V6 with four wire sensors.

***Please contact CP Performance for help with other applications.***

### **Pre Catalyst and Post Catalyst Oxygen Sensors**

All applications will have two oxygen sensors per cylinder bank, with one sensor located before the catalytic converter and one after the catalytic converter. It is common to call these sensors “pre-sensor” and “post sensor”, respectfully.

- a. Exhaust port
- b. Pre-catalyst oxygen sensor (located in the exhaust manifold collector)
- c. Catalytic converter
- d. Post catalyst oxygen sensor

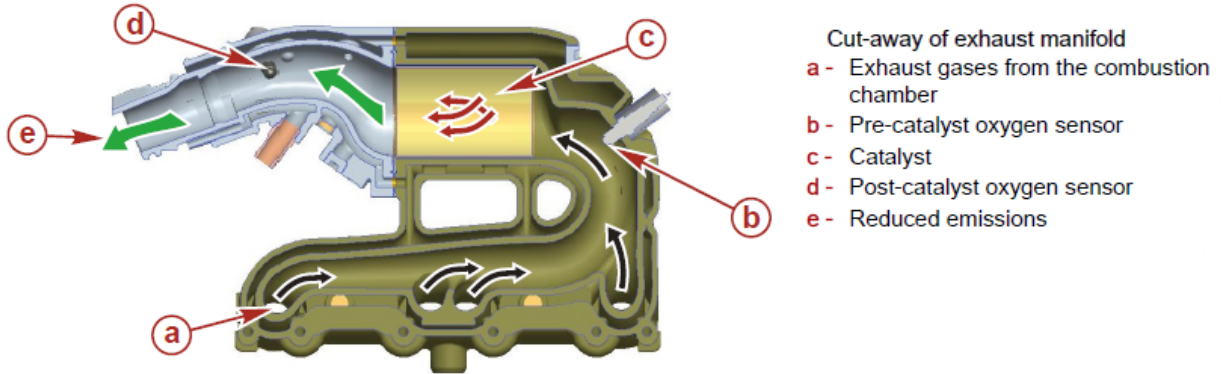

Figure 1 - Exhaust gas flow path and oxygen sensor locations, typical small block engine

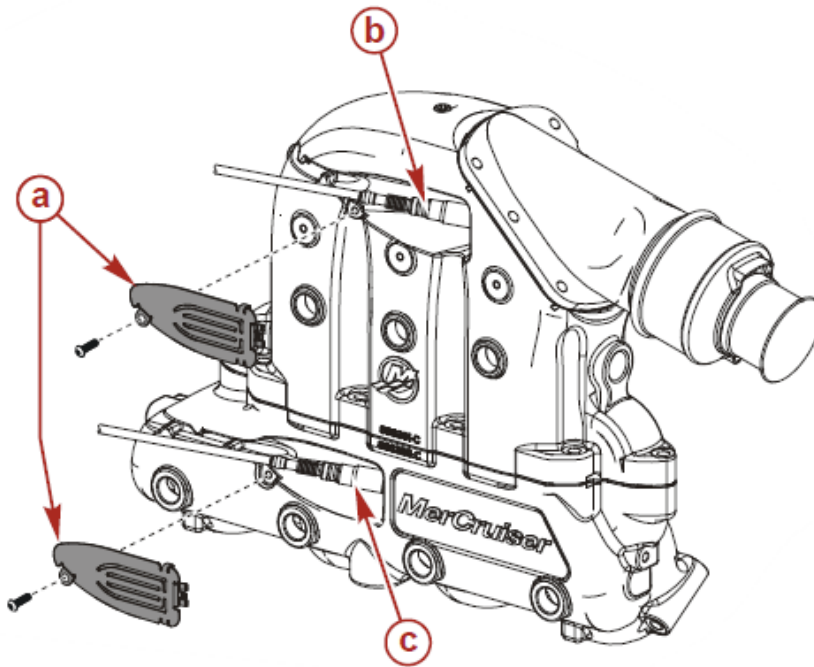

Figure 2 - Locations of Pre-Catalyst "c" and Post Catalyst Oxygen Sensors "b", typical big block engine

### **Purpose of the CEC**

The CEC will allow faults from the post oxygen sensor(s) or the catalyst(s) to be corrected such that the engine will run properly without turning on the Check Engine light due to these failed components. The Check Engine light will continue to function for all other faults. After the installation of the kit, the post catalyst oxygen sensor is no longer used and can be left in place as a plug or it can be removed and a steel plug (part number 620-50031) inserted in its place. The system will also function with or without the catalyst(s) in place.

The pre-catalyst oxygen sensor must function correctly in order for the CEC to work correctly. Prior to the CEC kit being installed, if the engine has a fault for the pre catalyst oxygen sensor(s), the fault will continue to be present after the CEC kit is installed. A pre catalyst sensor fault can usually be corrected by replacing the fuse for the oxygen sensor heater for this sensor or replacing the sensor itself. Pre, post, port, and starboard sensors are interchangeable.

### **The Catalyst Eliminator Computer Kit**

The CEC consists of a custom made computer and wiring harness assembly.



## Installing the CEC Harnesses to the Computer



Figure 3- The connector that attaches to the computer has an attaching screw with a  $\frac{1}{4}$ " head.

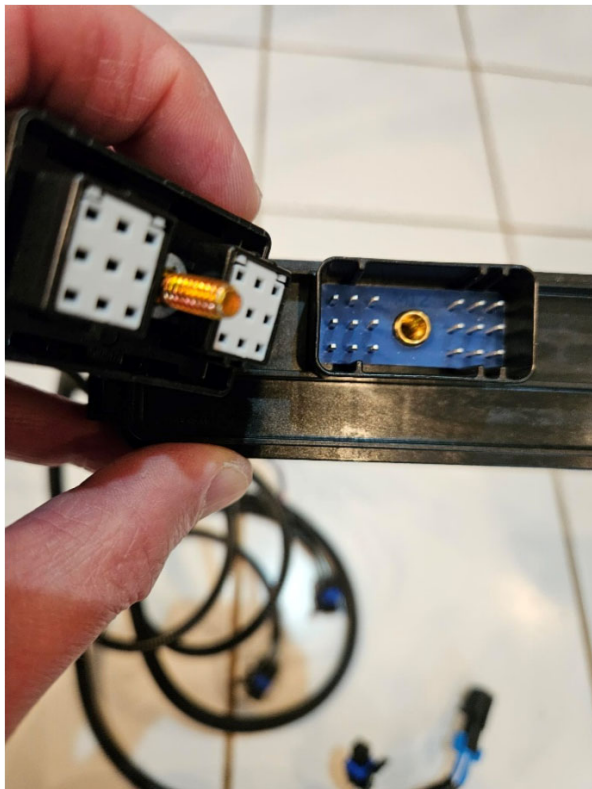
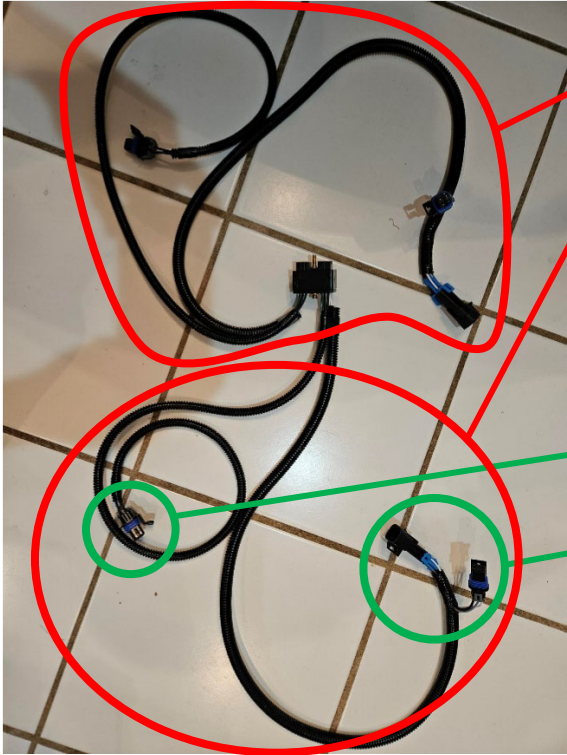

Figure 4-The 18-pin harness connector is to be inserted into the computer. It can be inserted only one way. The attaching screw is to be torqued to 15-20 inch-pounds.

The harness of the CEC Kit is made up of two branches. Each branch must feed one bank of a V8 or a V6 engine.



Each branch must feed one bank of a V8 or a V6 engine. If this step is not done correctly, the system will not function properly

Single connector will plug into the engine wiring harness where the post sensor use to connect

The double connectors will plug into the pre-oxygen sensor and it's mating connector from the engine wiring harness

Figure 5 – Each branch of the harness must go to the same engine bank

## General Method for Connecting the CEC Kit to the engine – V8 and V6

1. Connect the 18-pin CEC harness connector to CEC computer

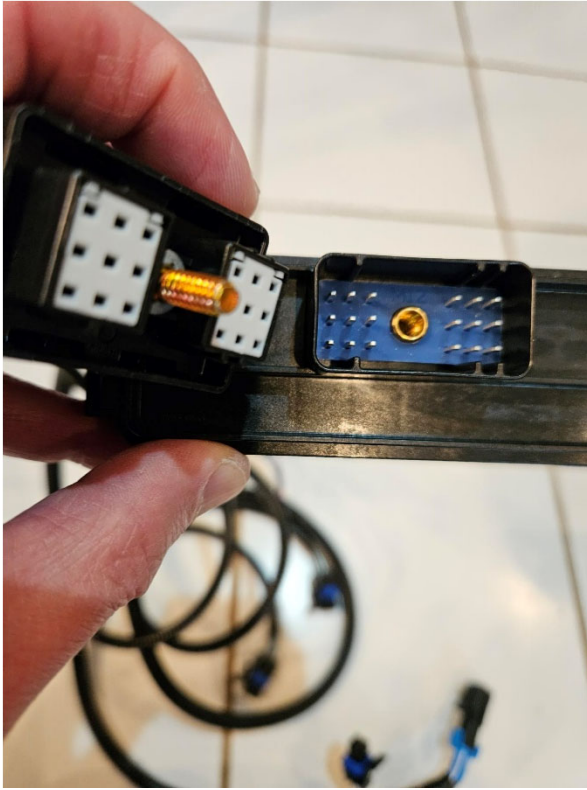

2. Route one branch of the harness to the left or right (port or starboard) side of the engine

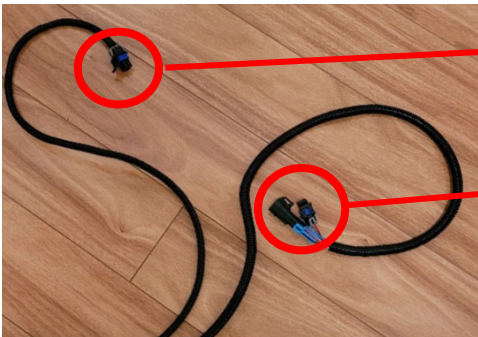

Single connector will plug into the engine wiring harness where the post sensor use to connect (step 5 below)

The double connectors will plug into the pre-oxygen sensor and it's mating connector from the engine wiring harness (step 7 below)

Figure 6 - The single connector and the double connector are routed to the same side of the engine

3. The following picture is applicable for all connections to any of the oxygen sensors



Figure 7 - Four wire oxygen sensor connector, "a" is the engine harness connector and "b" is the sensor connector

4. Disconnect the post oxygen sensor from the engine harness. The sensor can be left in place or removed and saved as a spare pre-sensor
5. Connect the single connector (step 2) into the engine harness where the post sensor was disconnected from in step 4
6. On the same engine bank as step 4, disconnect the pre-oxygen sensor from the engine harness
7. Connect the double connectors (step 2) to the pre-oxygen sensor and to the pre-oxygen sensor engine harness connector (they can only go together one way) from step 6
8. Route the second branch of the harness to the opposite side of the engine as the first branch of the harness from step 4
9. Disconnect the post oxygen sensor from the engine harness. The sensor can be left in place or removed and saved as a spare pre-sensor
10. Connect the single connector (step 2) into the engine harness where the post sensor was disconnected from step 9
11. On the same engine bank as step 9, disconnect the pre-oxygen sensor from the engine harness
12. Connect the double connectors (step 2) to the pre-oxygen sensor and to the pre-oxygen sensor engine harness connector (they can only go one way) from step 11
13. Mount the ECE computer to a cool location using the two mounting holes
14. Zip tie the wiring harnesses such that they will not interfere with moving or hot components